



# DTSC-50

## Automatic Transfer Switch Controller

### APPLICATIONS

The DTSC-50 digital transfer switch controller is an economical controller for open-transition (break before make) automatic transfer switch control.

#### Utility-to-Generator application

Utility is preferred with a generator as the emergency source

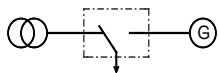

The DTSC-50 is intended for emergency stand-by applications with a single generator. When it detects a utility failure it commands the generator to start and transfers the load to the emergency source. When utility power is restored it performs an open-transition re-transfer and allows the engine to cool-down before stopping. It can be utilized in 1Ph2W, 1Ph3W, 3Ph3W and 3Ph4W Systems.

The DTSC-50 displays voltage and frequency values for each phase, as well as engine hours, maintenance hours and number of transfers. Active alarms are annunciated via the seven segment LED display. Separate LEDs show breaker status and source availability. Sealed soft-keys enable the user to start the generator and operate the transfer switch manually.

Password-protected programming can be accomplished through the front face or with a PC. Parameter limits and timers for utility and generator monitoring are freely programmable, adding a level of flexibility in the DTSC-50 not found in most lower-end ATS controls.

The unit is fully enclosed in a plastic housing for safety and has removable terminal blocks for easy wiring.

Open-transition transfer switch designs frequently use interposing relay logic to ensure that the utility and generator circuit breakers can't be closed at the same time, adding cost and wiring. The DTSC-50 uses breaker position reply signals to interlock the breakers internally, eliminating the need for external relays. The controller can also be configured to ignore breaker replies if they are unavailable, for instance in retrofit applications.

### DESCRIPTION

#### I/O set

- 1 or 3 phase generator and mains true rms voltage, measuring inputs: rated 480 Vac (max. 600 Vac)
- 2 configurable discrete inputs
- 3 programmable output relays

#### Protection & Monitoring

- **Protection**
  - Configurable fail and restore limits/timers for:
    - Over / under voltage      ANSI (59/27)
    - Over / under frequency    ANSI (81O/U)
    - Voltage balance            ANSI (47)
    - Phase rotation             ANSI (47)
- **Switch monitoring**
  - Switch position feedback
  - Transfer failure

#### Features

- Open transition transfer
- 6-digit, 7-segment LED for
  - display of measuring values (V, f)
  - display of counters
  - display of alarms
- Configurable trip levels/delays
- Customizable display using paper-strips
- Counters for:
  - Operation hours
  - Maintenance
  - Number of starts
  - Number of transfers
- Removable terminal blocks for easy wiring
- Configurable via PC and/or front panel
- Password protection

- AMF/loss of mains auto start/stop
- Open transition transfer
- Auto/manual operation
- Remote Start input
- "Lock in Auto mode" input
- "Lock in Manual mode" input
- Utility-to-Generator applications
- True R.M.S. voltage sensing
- LEDs for source availability and breaker status
- Freely configurable discrete I/O
- Adjustable timers
- Fully-enclosed housing
- Removable terminal blocks
- Internal breaker interlock utilizing discrete inputs for breaker position detection
- PC and/or front display configuration
- Password protection
- Eventlog ( 15 Events )
- UL/cUL Listed

# SPECIFICATIONS

Power supply..... 12/24 Vdc (6.5 to 32.0 Vdc)  
 Intrinsic consumption .....max. 10 W  
 Degree of pollution.....2  
 Ambient temperature (operation).....-20 to 70 °C / -4 to 158 °F  
 Ambient temperature (storage).....-20 to 85 °C / -4 to 185 °F  
 Ambient humidity.....95 %, non-condensing  
**Voltage** .....(Λ/Δ)  
 480 Vac Rated ( $V_{rated}$ ).....277/480 Vac  
 Maximum value ( $V_{max}$ ).....346/600 Vac  
 Rated voltage phase-ground.....300 Vac  
 Rated surge voltage.....4.0 kV  
 Linear measuring range ..... 1.3 x  $V_{rated}$   
 Measuring frequency..... 40 (mains) or 15 (generator) to 85 Hz  
 Accuracy .....Class 1  
 Input resistance.....2.0 MΩ  
 Max. power consumption per path.....< 0.15 W

**Discrete inputs** .....isolated  
 Input range..... 12/24 Vdc (6.5 to 32.0 Vdc)  
 Input resistance.....approx. 6.7 kΩ  
**Relay outputs** .....isolated  
 Contact material.....AgCdO  
 Load (GP) .....2.00 Aac@250 Vac  
 2.00 Adc@24 Vdc / 0.36 Adc@125 Vdc / 0.18 Adc@250 Vdc  
 Pilot duty (PD).....  
 1.00 Adc@24 Vdc / 0.22 Adc@125 Vdc / 0.10 Adc@250 Vdc  
**Housing** Flush-mount.....Type Woodward  
 Dimensions.....158×158×40 mm  
 Front cutout.....138[+1.0]×138[+1.0] mm  
 Connection.....screw/plug terminals 2.5 mm<sup>2</sup>  
 Tightening torque.....0.5 Nm  
**Housing**.....insulating surface  
 Protection system .....with correct installation  
 Front .....IP54 pending  
 Weight.....approx. 450 g  
**Disturbance test (CE)** .....tested according to applicable EN guidelines  
**Sinusoidal Vibration** .....4G, 5 to 100 Hz  
**Endurance Vibration**.....4G, 30 Hz, 1.5 h  
**Random Vibration**.....1.04Grms, 10 to 500 Hz, 2 h  
**Shock**.....40G peak, 11 ms  
**Listings**.....UL/cUL

# DIMENSIONS

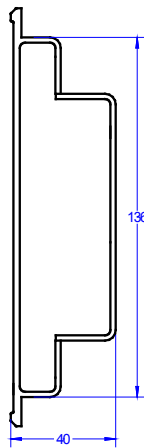
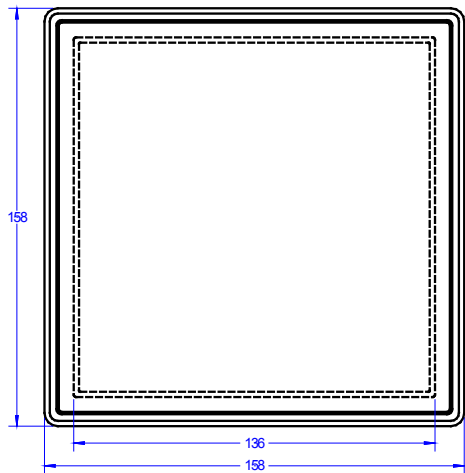

# WIRING DIAGRAM

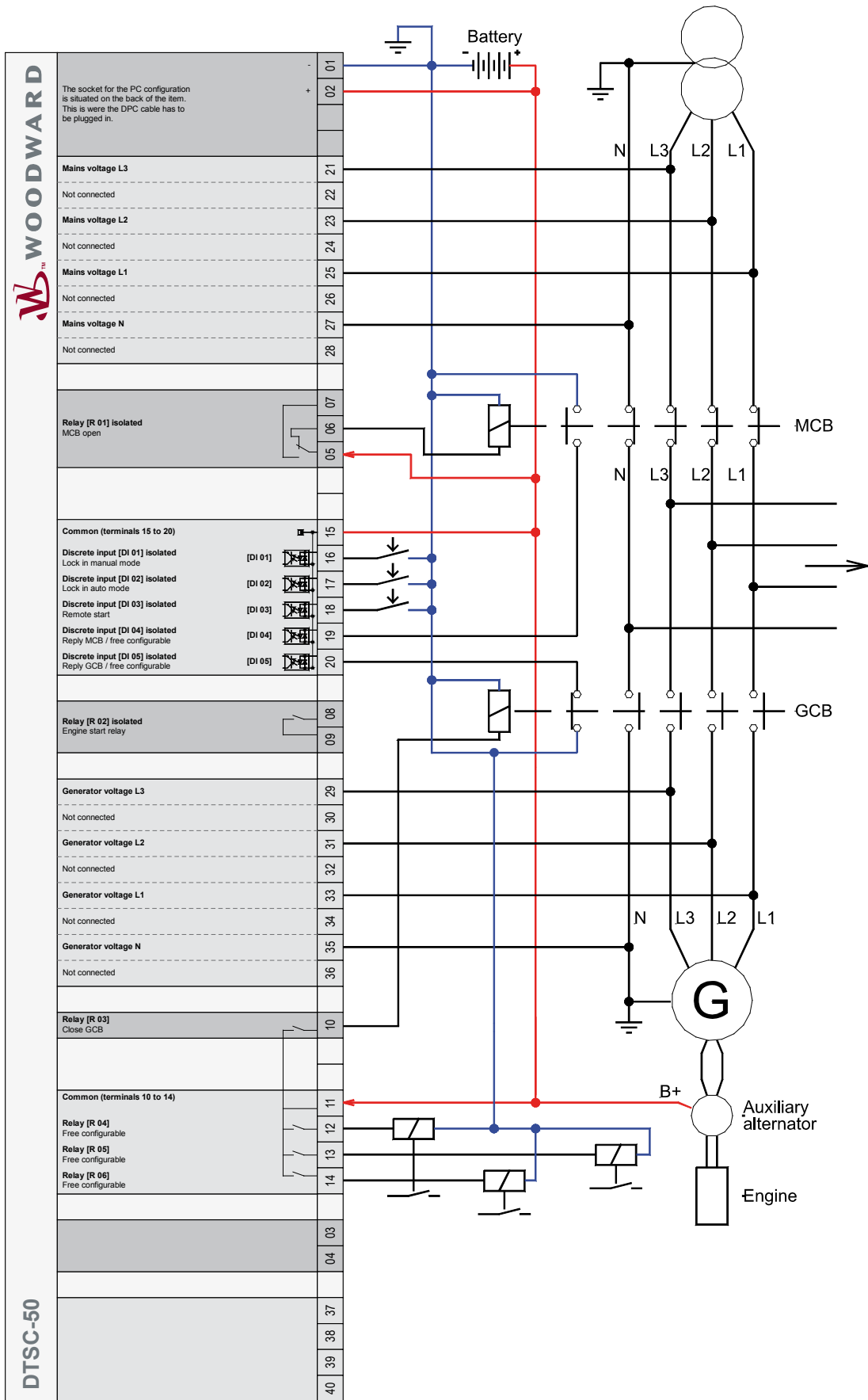

**International**

Woodward  
 PO Box 1519  
 Fort Collins CO, USA  
 80522-1519  
 1000 East Drake Road  
 Fort Collins CO 80525  
 Ph: +1 (970) 482-5811  
 Fax: +1 (970) 498-3058

**Europe**

Woodward GmbH  
 Handwerkstrasse 29  
 70565 Stuttgart, Germany  
 Ph: +49 (0) 711 789 54-0  
 Fax: +49 (0) 711 789 54-100  
 email: stgt-info@woodward.com

**Distributors & Service**

Woodward has an international network of distributors and service facilities. For your nearest representative, call the Fort Collins plant or see the Worldwide Directory on our website.

[www.woodward.com/power](http://www.woodward.com/power)

For more information contact:

Subject to technical modifications.

This document is distributed for informational purposes only. It is not to be construed as creating or becoming part of any Woodward Governor Company contractual or warranty obligation unless expressly stated in a written sales contract.

We appreciate your comments about the content of our publications. Please send comments including the document number below to [stgt-doc@woodward.com](mailto:stgt-doc@woodward.com)

© Woodward

**All Rights Reserved**

37455B - 2010/3/Stuttgart

# FEATURES OVERVIEW

Digital Transfer Switch Controller		DTSC-50
<b>Measuring</b>		
Source voltage (1phase/2-wire or 3phase/4-wire configurable)	rated 480 Vac	✓
- True R.M.S.	max 600 Vac	✓
<b>Breaker Control</b>		
Open transition (break-before-make)		✓
<b>Application</b>		
Utility to generator		✓
<b>Features</b>		
AMF/loss of utility, auto generator start/stop		✓
Display of measuring values (V, f), 6-digit, 7-segment LED		✓
Status LEDs for source availability and breaker state		✓
Configurable trip levels		✓
Adjustable timers		✓
Counters for operation and maintenance hours, number of transfers		✓
Fully-enclosed plastic housing for safety		✓
Removable terminal blocks		✓
Internal interlock prevents breakers from closing simultaneously		✓
Manual operation		✓
Flush-mounting (screw or clamp fastening)		✓
Configurable automatic mains stable timer bypass in case of a genset failure.		✓
Eventlog ( Max. 15 events – Readout via Serial interface only )		✓
<b>Accessories</b>		
Soft-keys		✓
Configuration via PC #1		✓
Password protection		✓
<b>Monitoring</b>		<b>ANSI#</b>
Source: voltage	59/27	✓
Source: frequency	810/81U	✓
Source: voltage asymmetry	47	✓
Source: Phase rotation error	47	✓
Switch: Open/close failure detection		✓
Engine : Start fail monitoring		✓
Engine : Unintended Stop monitoring		✓
<b>I/Os</b>		
"Lock in AUTO mode" input		1
"Lock in MANUAL mode" input		1
Configurable discrete inputs		2
Configurable discrete outputs		3
Discrete outputs for GCB and MCB control		2
Potential-Free Engine start contact (2 amp)		1
Direct configuration interface #1		✓
<b>Listings/Approvals</b>		
UL/cUL Listed		✓
<b>Part Numbers</b>		
Front panel mounting with display	P/N 8440-	1894

#1 Configuration software available free at Woodward.com, connection requires Woodward DPC cable P/N 5417-557